



COMPACT FLOWMETERS 615 SERIES

Metal Tube / Small Flow / Flow Alarm

FEATURES

- SUITABLE FOR SMALL FLOW OF LIQUIDS, STEAM OR GASES
- RIGID AND DURABLE BODY
- HIGH SAFETY AND RELIABILITY
- EASILY READABLE LARGE INDICATING SCALE
- ALARM DEVICE CAN BE ADDED
- LOW PRESSURE DROP
- VARIOUS CONNECTIONS & INSTALLATION LENGTH OF YOUR CHOICES

GENERAL SPECIFICATIONS

INDICATOR PORTION

Scale length : 75 mm (arch)
 Flowrate unit : L/H or specified
 Metering range : 1 : 10
 Accuracy : $\pm 2.0\%$ F.S.(Standard) / $\pm 1.5\%$ F.S.(Option)
 Repeatability : $\pm 0.8\%$ F.S.
 Max. Pressure drop : 250 ~ 400mm H₂O
 Damper : Optional damper are used if the measure system under unstable situation; normally 615 Series itself have provided with the function of stabilize indicator
 Material : Follower / 304SS
 Housing / ADC with epoxy coating or 316SS for specified
 Sight window / Safety glass Housing seal / Buna-N
 Enclosure : IP67 or Exd II B T4
 Ambient temperature : -20 to +60°C

METER TUBE PORTION

Pressure rating : ≤ 10 kg/cm²G (Standard)
 ≤ 100 kg/cm²G (Options)
 Operating temp. : -20 to +120°C (Standard)
 ≤ 300 °C (Options)
 Material : 304SS, 316SS, 316LSS or PTFE lining

ALARM DEVICE

ITEMS	SPECIFICATIONS
DETECTING MODE	Inductive Proximity Switch
CONTACT FORM	NAMUR NO (Inductive Proximity Switch)
POWER SUPPLY	8V Nor. (5~25V DC)
OPERATING CURRENT	8mA
NO-LOAD SUPPLY / CURRENT CONSUMPTION	≤ 1 mA at detecting ≥ 3 mA at No-detecting
ELECTRIC PROTECTION	PTB NO.99 ATEX 2219X II 1/2G EEx ia IIC T6
EMC DESIGN & TESTING	According to EN 60947-5-2 & DIN EN 60947-5-6 (NAMUR)
ENCLOSURE CLASS	IP67
SETTING RANGE	10~100% adjustable and 15% gap for H/L alarm
ALARM SETTING	The switch with a screw can be set on the slot of scale
AMBIENT TEMP.	-25~+70°C
ACCESSORIES (OPTIONAL)	Safety Barrier KFD2/KFA6 (DC/AC) or MTL5011B / 5018 DC system (Prox input / Relay output)
ELECTRICAL CONNECTION	With a cable gland (PG9) for standard or DIN 43650 Connector or 1/2"NPT(F) for Explosion-proof are specified versions (Class I Div.1, Gr.B/C/D/E/F/G)



STRUCTURE & PRINCIPLE

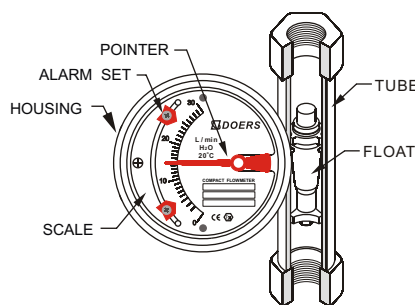

WIRING CONNECTION

FOR INTRINSIC SAFETY SYSTEM

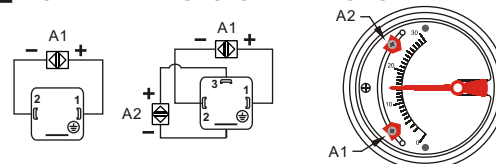

EXPLOSION-PROOF VERSION (Class I Div.1, Gr.B/C/D/E/F/G)

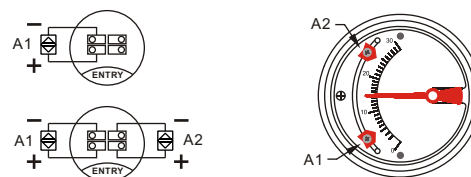

EXAMPLE OF SYSTEM CONFIGURATION

AC POWER SYSTEM

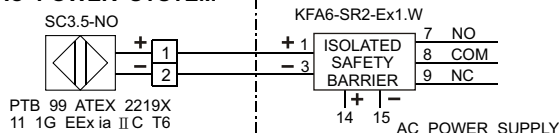

DC POWER SYSTEM

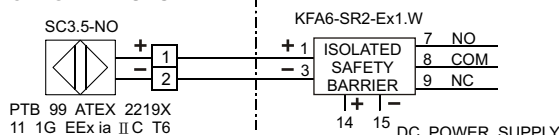

HAZARDOUS AREA ← → SAFETY AREA

MODEL SELECTION

ITEMS	CODE	SPECIFICATIONS			
① MODEL (Connection type)	615A	Thread connection type			
	615B	Flange connection type			
	615C	To be specified			
② ALARM DEVICE	-0	Not required (Indicator only)			
	-1	NAMUR without safety barrier			
	-2	NAMUR with DC safety barrier			
	-3	NAMUR with AC safety barrier			
	-4	To be specified			
③ ALARM POINTS	0	Indicator without alarm device			
	1	With 1 point alarm device			
	2	With 2 points alarm device			
	3	To be specified			
④ CONNECTION	CODE	615A		615B	
	0	NPT(F)		ANSI 150 ^{lb} Flange	
	1	PT(F)		JIS 10K Flange	
	2	To be specified			
⑤ MATERIAL OF WETTED PARTS	CODE	FLANGE	MEASURING TUBE	FLOAT/DAMPER	INDICATING HOUSING
	0	304SS (1.4301)	304SS (1.4301)	304SS (1.4301)	Aluminum alloy with epoxy coating
	1	316SS (1.4571)	316SS (1.4571)	316SS (1.4571)	
	2	316LSS	316LSS	316LSS	
	3	PVDF/PTFE Lining	PVDF/PTFE Lining	PVDF/PTFE Lining	316SS
	4	304SS (1.4301)	304SS (1.4301)	304SS (1.4301)	
	5	316SS (1.4571)	316SS (1.4571)	316SS (1.4571)	
	6	316LSS	316LSS	316LSS	
	7	PVDF/PTFE Lining	PVDF/PTFE Lining	PVDF/PTFE Lining	
8	To be specified				
⑥ INSTALLATION LENGTH	-A	Standard (See dimensions table)			
	-B	To be specified			
⑦ FLOW DIRECTION	A	Standard (Bottom to top)			
	B	To be specified			
⑧ OPERATING TEMPERATURE (OPTIONAL COOLING PARTS)	A	Standard (-20~+120°C)			
	B	≤200°C			
	C	≥201°C ≤300°C			
	D	To be specified			
⑨ OPTIONAL ACCESSORIES	A	Not required			
	B	Inlet adjusting valve			
	C	Outlet adjusting valve			
	D	Magnetic filter			
	E	Damper (Assembled on inner of indicator housing)			
	F	Constant flow unit for inlet variation used			
	G	Constant flow unit for outlet variation used			
	H	To be specified			
⑩ METER SIZE	-006	6A (1/4")			
	-025	25A (1")			
	-xxx	To be specified			
⑪ EXTRA TREATMENT	A	Not required (For General purpose)			
	B	High purity cleaning (HPC)			
	C	Electro-polishing (EP)			
	D	Special finished (Painting or coating)			
	E	Explosion proof housing (Exd II B T4, IP67)			
	S	To be specified			

Note : We accept special orders to fit your requirements.

STANDARD DIMENSIONS (m/m)

615A

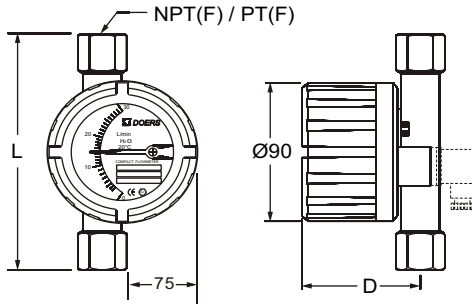

METER SIZE mm (in.)	MAX. FLOW RANGE		ΔP mmH ₂ O	DIMENSIONS	
	Water 20°C	Air at 1atm 0°C		L (mm)	D (mm)
6 (1/4")	6 L/H	180 NL/H	250	180	85
8 (3/8")	15 L/H	300 NL/H	270	180	85
10 (3/8")	30 L/H	600 NL/H	270	180	85
15 (1/2")	900 L/H	25000 NL/H	280	180	88
20 (3/4")	1200 L/H	32000 NL/H	350	180	91
25 (1")	3000 L/H	80000 NL/H	400	200	94

FLOW RATE : 1 : 10

615B

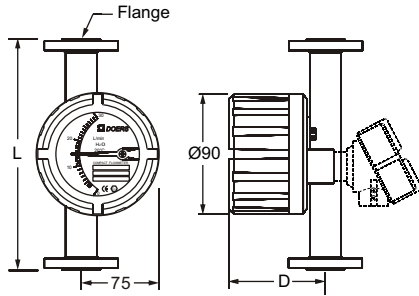

METER SIZE mm (in.)	MAX. FLOW RANGE		ΔP mmH ₂ O	DIMENSIONS	
	Water 20°C	Air at 1atm 0°C		L (mm)	D (mm)
15 (1/2")	30 L/H	600 NL/H	270	250	85
15 (1/2")	900 L/H	25000 NL/H	280	250	88
20 (3/4")	1200 L/H	32000 NL/H	350	250	91
25 (1")	3000 L/H	80000 NL/H	400	250	94

FLOW RATE : 1 : 10

OPTIONAL ACCESSORIES

Inlet / Outlet Adjusting Valve

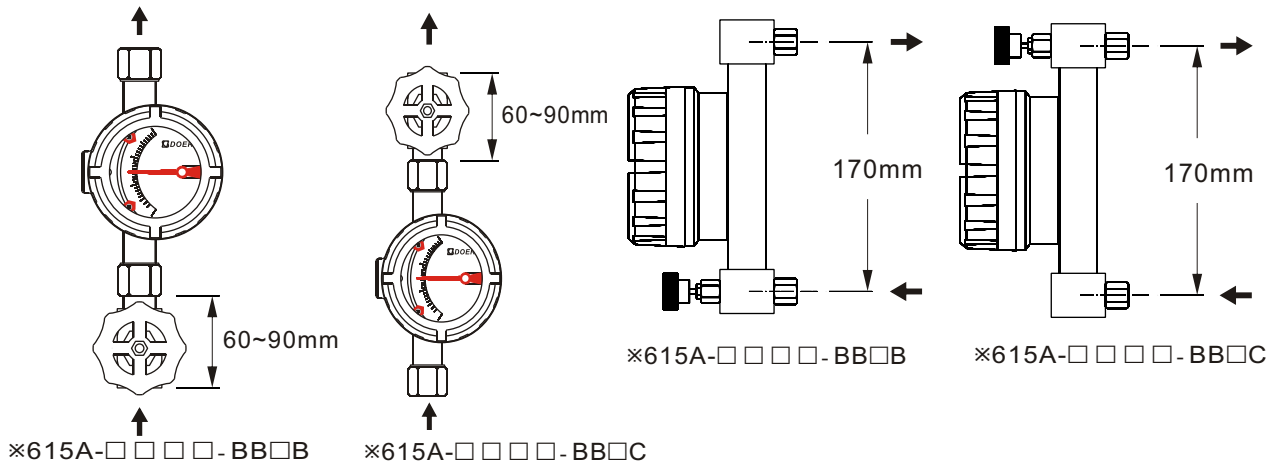

⑥ FLOW

Magnet Filter

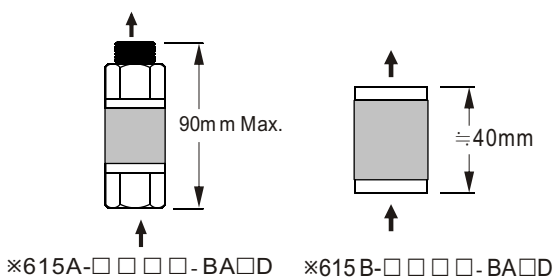

Inlet / Outlet Constant Flow Unit

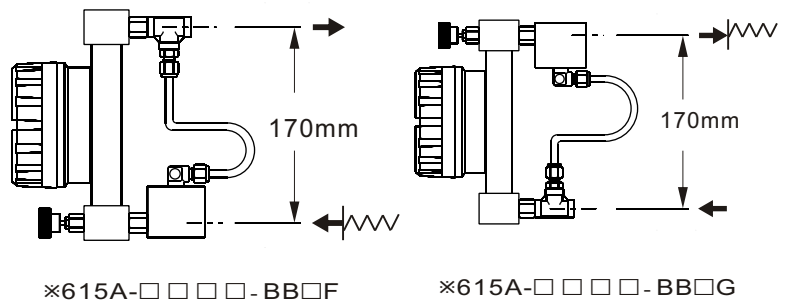

PIPELINE PLANNING

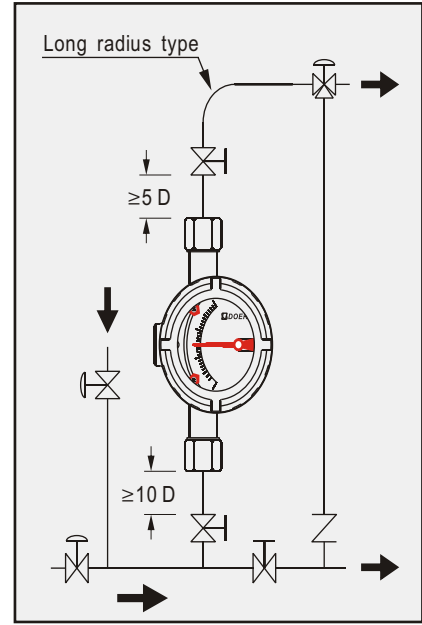
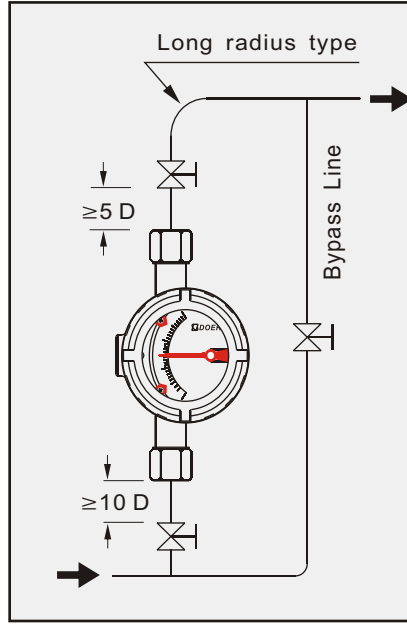
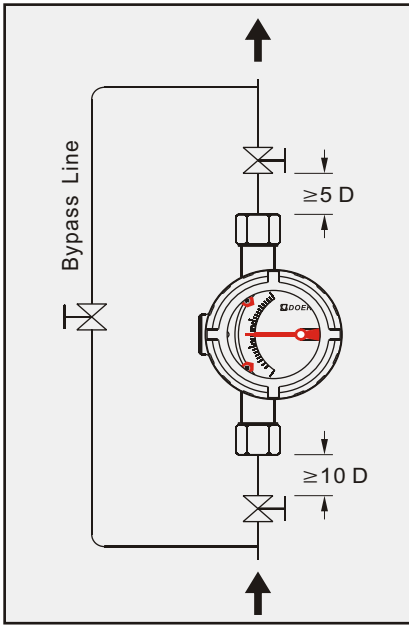

INSTRUCTIONS

SUITABLE RANGE FOR THE LIQUID VISCOSITY

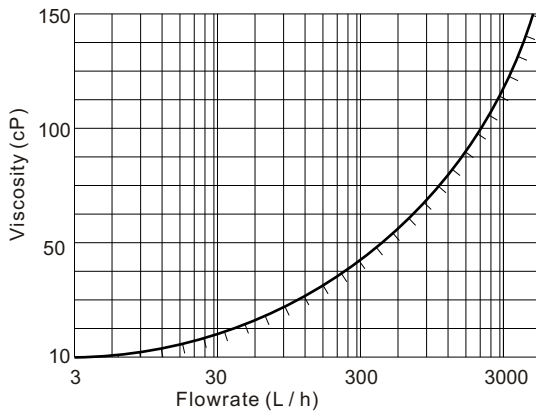

PIPE SIZE OF STEAM FLOWS

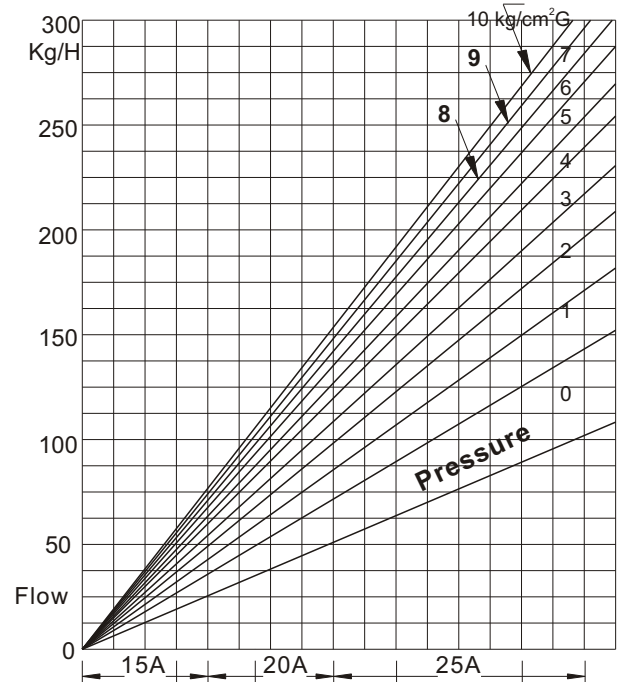

⑥ FLOW

GAS FLOW CALCULATION

When the gas flowmeter is different from the ordered specifications, errors in measurement may occur. In this case, further calculation is necessary. The formula is as follows:

$$Q_a = Q_g \times \sqrt{\frac{\gamma}{1.293}} \times \sqrt{\frac{1.033}{(1.033+P)}} \times \sqrt{\frac{(273+t)}{273}}$$

Q_a : Air flowrate for converted result (M^3/H)

Q_g : Flowrate of the gas to be metered (M^3/H)

γ : Density of the gas to be metered (kg/NM^3)

P : Operating pressure (kg/cm^2G)

t : Operating temperature ($^{\circ}C$)

DOERS TECHNOLOGY CORPORATION

4F, NO. 1, LANE 11, TZU-CHIANG STREET, TU-CHENG INDUSTRIAL PARK, TAIPEI COUNTY, TAIWAN 23678

<http://www.doers.com.tw>

E-mail: doers.tech@msa.hinet.net

TEL: 886-2-22682689

FAX: 886-2-22681248

