

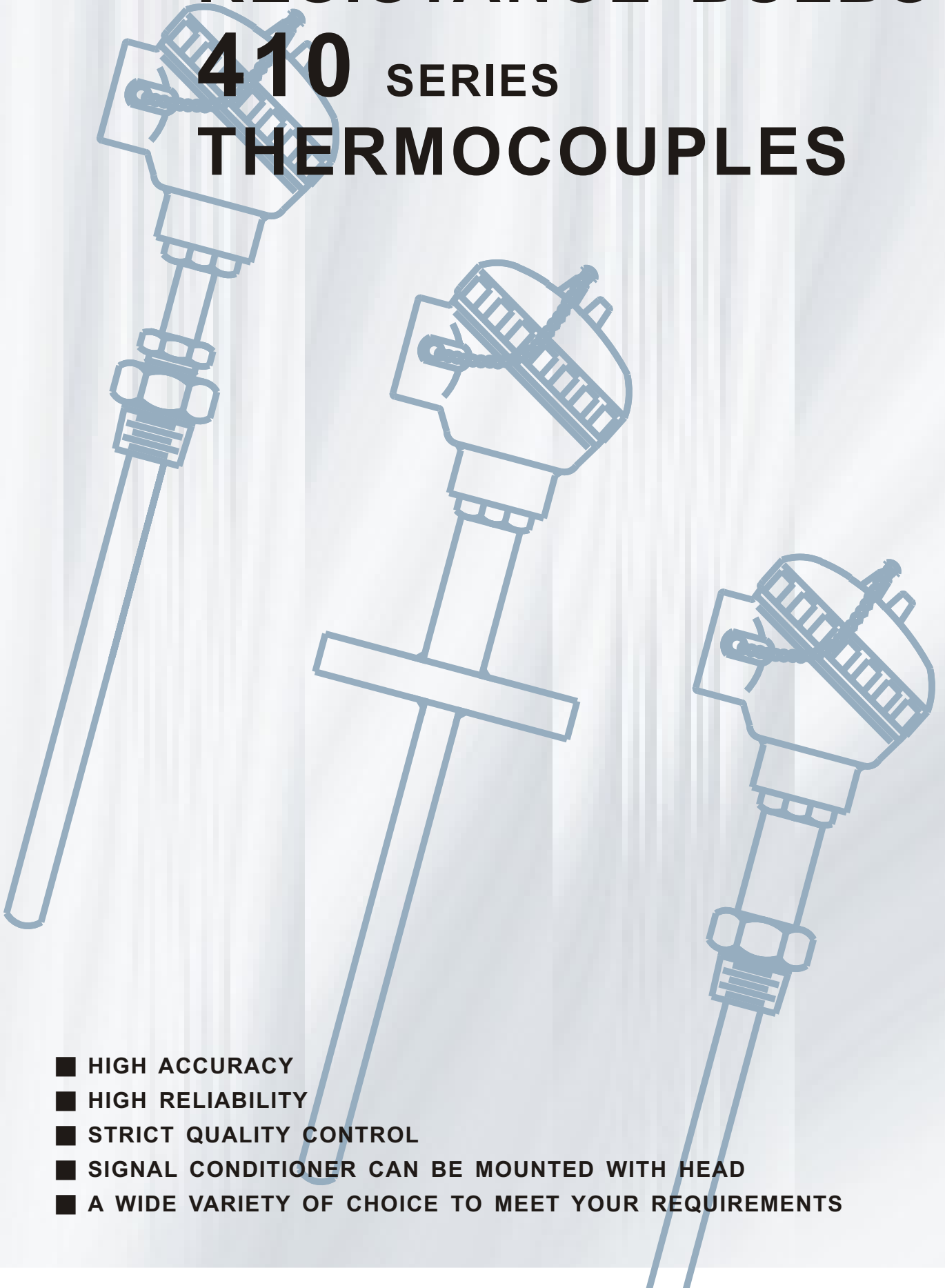

400 SERIES RESISTANCE BULBS

410 SERIES THERMOCOUPLES



- HIGH ACCURACY
- HIGH RELIABILITY
- STRICT QUALITY CONTROL
- SIGNAL CONDITIONER CAN BE MOUNTED WITH HEAD
- A WIDE VARIETY OF CHOICE TO MEET YOUR REQUIREMENTS

RESISTANCE BULBS / SHEATH RTD

■ STRUCTURE & PRINCIPLE

The principle of resistance bulb is to make use of resistance of pure metal wire to measure temperature. The resistance value will rise with certain ratio as temperature increases. The RTD consists of a pure gold wire which winds around a slender mica or glass and then coats a protection mica cover or adds a ceramic enclosure with 2 / 3 lead wire. The RTD element is put in a protection tube and connected to a head to become a complete set.

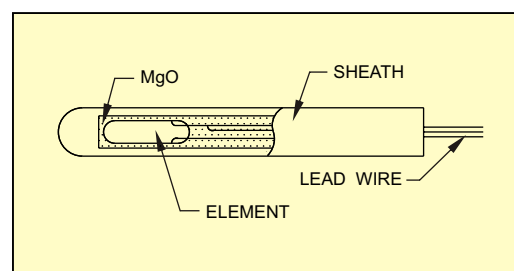

■ ALLOWABLE ERROR FOR Pt100 (DIN 43760)

ITEMS		A (0.2)	B (0.5)
TEMP. ERROR		$\pm 0.15 + 0.002t$	$\pm 0.3 + 0.005t$
RESISTANCE ERROR		$\pm 0.06 \Omega$	$\pm 0.12 \Omega$
RESISTANCE RATIO		$R_{100} / R_0 = 1.3850$	
MEASURING TEMP.	GENERAL PURPOSE	0 ~ +350°C	
	LOW TEMP.	-200 ~ +100°C	
	HIGH TEMP.	0 ~ +650°C	
CURRENT		1 mA, 2 mA	5 mA

■ WIRING CONNECTIONS

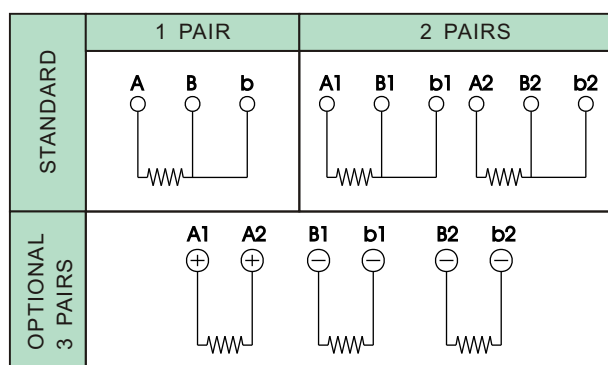

■ PROTECTION TUBE / INSULATION SELECTIONS

ITEMS		RTD OF UNIVERSAL	SHEATH RTD
O.D. OF PROTECTION TUBE	1 PAIR	6, 8, 10, 12, 15, 17, 22	3.2, 4.8, 6.4, 8.0
	2 PAIRS	6, 8, 10, 12, 15, 17, 22	4.8, 6.4, 8.0
	3 PAIRS	8, 10, 12, 15, 17, 22	None
MATERIAL OF PROTECTION TUBE		SUS304, SUS316, Hastelloy-C, PTFE coating or specially specified	SUS304, SUS316, SUS321, SUS310 Inconel-600 or specially specified
INSULATION MATERIAL		Teflon tube (st'd) / MgO filled or specified	MgO filled or specified

■ RESISTANCE VALUE FOR Pt 100Ω (DIN 43760 IEC 751 & JIS -1606)

UNIT : Ω

°C (°F)	0	-10	-20	-30	-40	-50	-60	-70	-80	-90	-100
-100 (-148)	60.25	56.19	52.11	48.00	43.87	39.71	35.53	31.32	27.08	22.80	18.49
0 (32)	100.00	96.09	92.16	88.22	84.27	80.31	76.33	72.33	68.33	64.30	60.25
°C (°F)	0	10	20	30	40	50	60	70	80	90	100
0 (32)	100.00	103.90	107.79	111.67	115.54	119.40	123.24	127.07	130.89	134.70	138.50
100 (212)	138.50	142.29	146.06	149.82	153.58	157.31	161.04	164.76	168.46	172.16	175.84
200 (392)	175.84	179.51	183.17	186.82	190.45	194.07	197.69	201.29	204.88	208.45	212.04
300 (572)	212.02	215.57	219.12	222.65	226.17	229.67	233.17	236.65	240.13	243.59	247.04
400 (752)	247.04	250.48	253.90	257.32	260.72	264.11	267.49	270.86	274.22	277.56	280.90
500 (932)	280.90	284.22	287.53	290.83	294.11	297.39	300.65	303.91	307.15	310.38	313.59
600 (1,112)	313.59	316.80	319.99	323.18	326.35	329.51	332.66	335.79	338.92	342.03	345.13
700 (1,292)	345.13	348.22	351.30	354.37	357.42	360.47	363.50	366.52	369.53	372.52	375.51
800 (1,472)	375.51	378.48	381.45	384.40	387.34	390.26	—	—	—	—	—

THERMOCOUPLES / SHEATH THERMOCOUPLES

■ STRUCTURE & PRINCIPLE

Each thermocouple comprises two dissimilar metal wires welded together to become a hot junction. When the hot junction is heated, the EMF value will be affected. The difference between the EMF values of hot junction and cold junction that transforms thermal energy to electricity is called the Seebeck effect. The diameter of element of thermocouple will not affect the EMF, but the extension wire are related to the EMF output accuracy. The thermocouple element is usually put in a protection tube and/or connected to a head to become a complete set.

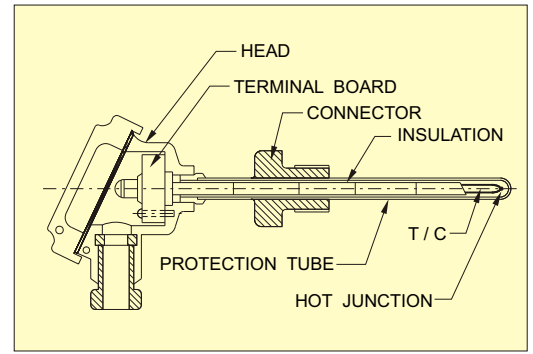

■ ALLOWABLE ERROR OF T/C ELEMENT/DIA. SELECTION OF PROTECTION TUBE

CODE		B	R	S	K		E		J		T	
WIRE ELEMENT		B	R	S	K		E		J		T	
INGREDIENTS	+	Platinum Rh 30%	Platinum Rh 13%	Platinum Rh 10%	Ni 90% Cr 10%				Fe		Cu	
	-	Platinum Rh 6%	Platinum		Ni 94% Al 3%	Mn 2% Si 1%			Cu 55% Ni 45%			
CLASS 1	LIMIT	—	0°C } 1100°C	—	-40°C } 375°C	375°C } 1000°C	-40°C } 375°C	375°C } 800°C	-40°C } 375°C	375°C } 750°C	-40°C } 125°C	125°C } 350°C
	ERROR	—	±1°C	—	±1.5°C	±0.4% F.S.	±1.5°C	±0.4% F.S.	±1.5°C	±0.4% F.S.	±0.5°C	±0.4% F.S.
CLASS 2	LIMIT	600°C~1700°C	0°C } 600°C	600°C } 1600°C	-40°C } 333°C	333°C } 1200°C	-40°C } 333°C	333°C } 900°C	-40°C } 333°C	333°C } 750°C	-40°C } 133°C	133°C } 350°C
	ERROR	±0.25% F.S.	±1.5°C	±0.25% F.S.	±2.5°C	±0.75% F.S.	±2.5°C	±0.75% F.S.	±2.5°C	±0.75% F.S.	±1.0°C	±0.75% F.S.
CLASS 3	LIMIT	600°C } 800°C	800°C } 1700°C	—	-167°C } 40°C	-200°C } 167°C	-167°C } 40°C	-200°C } 167°C	—	—	-67°C } 40°C	-200°C } -67°C
	ERROR	±4% F.S.	±0.5% F.S.	—	±2.5°C	±1.5% F.S.	±2.5°C	±1.5% F.S.	—	—	±1.0°C	±1.5% F.S.
DIAMETER		0.5			0.65,1.0,1.6,2.3,3.2		0.32,0.65,1.0,1.6		0.65,1.0,1.6,2.3		0.3,0.65,1.0,1.6	
O.D. OF PROTECTION TUBE	METAL	—			10, 12, 15, 17, 22		10, 10, 12, 15		10, 12, 15, 22		10, 10, 12, 15	
	NONMETAL	15			10, 15, 15, 17, 17		—		10, 15, 15, 17		—	
BUILT-IN		3 PAIRS max.			3, 2, 2, 2, 3 PAIRS		3, 3, 2, 2 PAIRS		3, 2, 2, 3 PAIRS		3, 3, 2, 2 PAIRS	

■ EMF

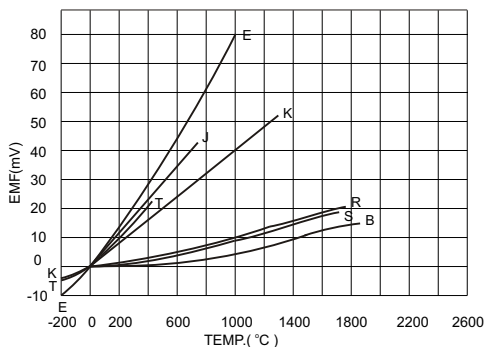



■ HOT JUNCTIONS

TYPE	CODE	FEATURES
	C	It is a quick response type, and is used for high temperature / high pressure. But it is unsuitable to be put in a voltage grounding system and noise / hazardous area.
	D	It is a general type and has steadier sensing, suitable to be used in noise / hazardous area.
	E	It is the quickest response type. Due to bad enclosure, it is unsuitable for high temperature / high pressure or corrosive site.

THERMOCOUPLES / SHEATH THERMOCOUPLES

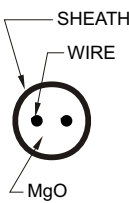
■ STRUCTURE OF SHEATH THERMOCOUPLES

VIEW	O.D. (mm)	THICK (mm)	WIRE (mm)	SHEATH MATERIAL	MAX. LENGTH	Loop Resistance Ω / m at 20°C			
						K	E	J	T
ONE PAIR 	0.25	0.05	0.04	Inconel-600	5 m	600.0	—	—	—
	0.5	0.09	0.09		50 m	152.5	191.9	106.3	—
	1.0	0.15	0.18		100 m	38.6	48.6	26.4	22.2
	1.6	0.23	0.28		300 m	15.5	19.6	10.7	9.1
	2.2	0.33	0.40		300 m	8.1	10.5	5.6	4.7
	3.2	0.48	0.58		160 m	3.9	5.5	2.7	2.3
	4.8	0.71	0.84		60 m	1.8	2.3	1.3	1.0
	6.4	0.94	1.12		40 m	1.1	1.3	—	—
	8.0	1.17	1.37		25 m	0.7	0.8	0.5	0.4
	TWO PAIRS 	1.6	0.23		0.23	Inconel-600 SUS304 SUS316 SUS321 SUS310 or specified	300 m	21.0	28.7
2.2		0.33	0.33	300 m	10.7		—	7.4	6.3
3.2		0.48	0.46	160 m	5.9		7.2	3.8	2.8
4.8		0.74	0.71	70 m	2.5		2.9	1.5	1.1
6.4		1.02	0.94	40 m	1.6		1.7	1.0	0.7
8.0		1.24	1.24	25 m	1.0		1.1	0.6	0.5
THREE PAIRS 		3.2	0.33	0.28			160 m	26.8	—
	4.8	0.46	0.38	70 m		11.9	—	—	—
	6.4	0.64	0.48	40 m		6.7	—	—	—
	8.0	0.79	0.61	25 m		4.3	—	—	—

■ SELECTION OF CORE FOR EXTENSION WIRE

CODE	1	2	3	4	5	6
COVER MATERIAL	HOT RESISTANCE PVC		GLASS FIBER		TEFLON	
WIRE DIA.(mm) / CORE	0.32 / 1C	0.65 / 1C	0.32 / 4C	0.65 / 4C	0.32 / 7C	0.65 / 7C
SECTIONAL AREA (mm ²)	0.08	0.3	0.3	1.3	0.5	2.3
AMBIENT	-10~+100°C		-10~+270°C		-100~+260°C	

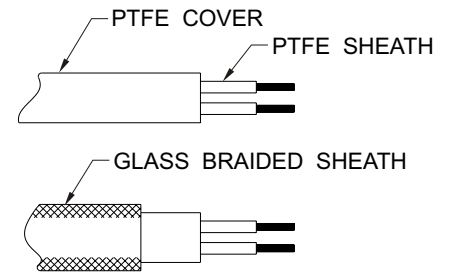

■ SELECTION OF EXTENSION WIRE

USAGE T / C	WIRE CODE	COLOR	APPLICATION / GRADE	MATERIAL	OPERATING TEMP. (°C)	PERMITTED ERROR (°C)	LOOP RESISTANCE Ω /m	
B	BX-G	Grey	General purpose / universal	Positive pole : Copper Negative pole : Copper	0~100	—	0.05	
R / S	RX-G	Black	General purpose / universal	Positive pole : Copper-Nickel Negative pole : Copper	0~100	+3	0.1	
	SX-G		Hot resistant / universal		0~150	-7		
	RX-H				Hot resistant / universal	-20~100		±2.5
	SX-H		-20~150			±1.5		
K	KX-G	Blue	General purpose / universal	Positive pole : Nickel-Chromium Negative pole : Copper	-20~100	±2.0	1.5	
	KX-GS		General purpose / High precision		-20~150	±1.5		
	KX-H		Hot resistant / universal		-20~100	±2.5		
	KX-HS		Hot resistant / High precision		-20~150	±2.0		
	WX-G		General purpose / universal	Positive pole : Iron Negative pole : Copper-Nickel	-20~100	±1.5	0.5	
	WX-H		Hot resistant / universal	-20~150				
	VX-G		General purpose / universal	Positive pole : Copper Negative pole : Copper-Nickel	-20~100			±3.0
E	EX-G	Purple	General purpose / universal	Positive pole : Nickel-Chromium Negative pole : Copper-Nickel	-20~100	±3.0	1.5	
	EX-H		Hot resistant / universal		-20~150			
J	JX-G	Yellow	General purpose / universal	Positive pole : Iron Negative pole : Copper-Nickel	-20~100	±3.0	0.8	
	JX-H		Hot resistant / universal		-20~150			
T	TX-G	Brown	General purpose / universal	Positive pole : Copper Negative pole : Copper-Nickel	-20~100	±2.5	0.8	
	TX-GS		General purpose / High precision		±2.0			
	TX-H		Hot resistant / universal		-20~150	±1.0		0.8
	TX-HS		Hot resistant / High precision					

● The red wire is positive pole while the white wire is negative.

CONNECTIONS & PROTECTIVE TUBE

THE CONNECTION & EXTENSION PORTION—"N"

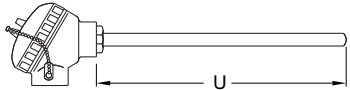
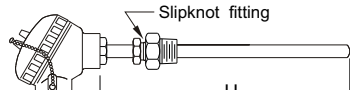
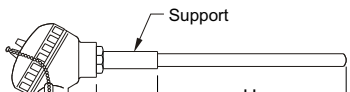
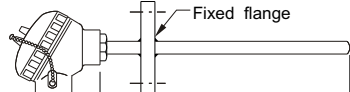
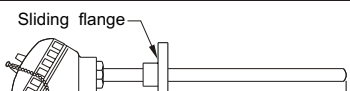
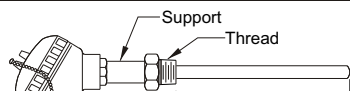
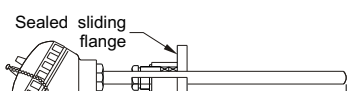
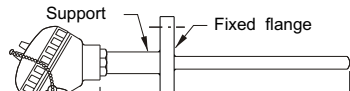
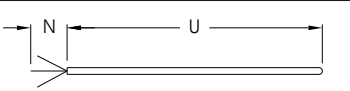
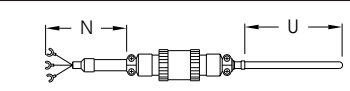
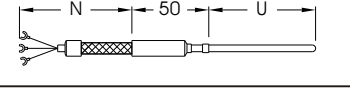
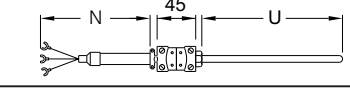
CODE	EXTERNAL VIEW	PURPOSE	CODE	EXTERNAL VIEW	PURPOSE
A		Thermocouple / RTD	E		Thermocouple / RTD
		SHEATH TC / RTD			SHEATH TC / RTD
B		Thermocouple	F		Thermocouple / RTD
		SHEATH TC			SHEATH TC / RTD
C		Thermocouple / RTD	G		Thermocouple / RTD
D		Thermocouple / RTD	H		Thermocouple / RTD
1		SHEATH TC / RTD	3		SHEATH TC / RTD
2		SHEATH TC / RTD	4		SHEATH TC / RTD

PROTECTION TUBE OF PART"U"

TYPES	CODE	MATERIALS	O.D. OF PROTECTION TUBE (mm)	OPERATING TEMP. (°C)		APPLICATIONS
				Nor.	Max.	
METALS	0	SUS304	3.2 / 4.8 / 6.8	750	850	General purpose
	1	SUS316	10 / 12 / 15	850	950	Used for corrosive
	2	SUS316L	17 / 22			
	3	Hastelloy-C	Specially specified	1090	1150	Used for corrosive and high-temp.
	4	Other metals				As service requirements
NONMETAL	5	Pure Al ₂ O ₃ JIS PT0 (99.5%) PT0 DIN 710 (99.7%)	6 / 8 / 10 / 13 15 / 17 / 21	1600	1800	Used for superhigh temperature
	6	Al ₂ O ₃ JIS PT1 (55%) PT1 DIN 610 (58%)		1500	1600	
	7	Al ₂ O ₃ JIS PT2 (45%) PT2		1400	1500	
	8	Quartz-"QT"	Specially specified	1000	1100	Used for sudden changes in temperature
	9	Other nonmetals				As service requirements

DIMENSION OF HEADS (mm)

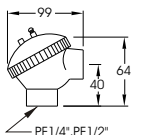
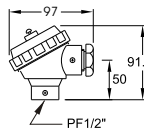
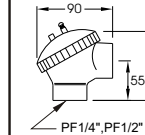
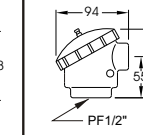
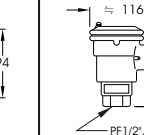
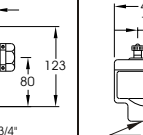
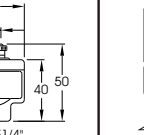
CODE	A	B	C	D	E	F	G
VIEW							

MODEL SELECTIONS

ITEMS	SPEC.	RTD			SHEATH RTD			
		400	401	402	403	404	405	
① MAIN TYPE		★ Class-B 0~+350°C	Class-A 0~+350°C	Specially specified	★ Class-B 0~+350°C	Class-A 0~+350°C	Specially specified	
		THERMOCOUPLE			SHEATHED THERMOCOUPLE			
		410	411	412	413	414	415	416
		★ Class-3	Class-2	Class-1	★ Class-3	Class-2	Class-1	Specified for thermocouples / sheath
② HEAD	A	Material : ADC-12 Structure : IP67 Cable entry : BSP 3/8" Terminal board : 2P / 3P / 4P		D	Material : Bakelite Structure : IP66 Cable entry : PF 1/2" Terminal board : 2P / 3P / 4P / 6P		G	Material : ADC-12 Structure : Unsheltered Terminal board : 2P
	B	Material : Bakelite Structure : IP66 Cable entry : PF 3/8" Terminal board : 2P / 3P / 4P		E	Material : ADC-12 Structure : Explosion proof Cable entry : PF / PT 1/2" , 3/4" Terminal board : 2P / 3P / 6P		H	Specially specified (The detail as notes)
	C	★ Material : ADC-12 Structure : IP67 Cable entry : NPT 1/2" Terminal board : 2P / 3P / 4P / 6P		F	Material : ADC-12 Structure : Unsheltered Terminal board : 2P / 3P		J	With lead wire (No head versions)
	NOTES	① Material of terminal board Standard : Bakelite / Option : Ceramic ② Connection size of cable entry can be specified			③ The finished head is silver painted. The corrosive resistance must be specified. ④ Other head style & material can be provided			
③ CONNECTION & PART "N" (See page 4)	GENERAL			SHEATH USED				
	A	★ Only protection tube (Non any connector)	E	Slipknot style		1	Wire exposed	
			F	Fixed flange		2	With extension wire and not with any connector	
	B	Protection tube with support collar	G	Fixed thread with support		3	With a water-proof connector	
			H	Fixed flange with support		4	With a connector of plug-in style	
	C	Sliding flange	N	Specially specified		5	Specially specified	
④ CONNECTION	0	★ None						
	THREAD	1	2	3	4	5	6	
		1/4"PT	3/8"PT	★ 1/2"PT	3/4"PT	1"PT	Specified but without flange	
	FLANGE	ANSI 150#	A		B	C	D	E
			★ 1/2"		3/4"	1"	1 1/2"	2"
	JIS 10K	F		G	H	J	K	
		1/2"		3/4"	1"	1 1/2"	2"	
	Other	L	Specified but without thread					
⑤ MATERIAL OF CONN. & PART "N"	0	1		2	3	4	5	
	★ None / For sheath	★ SUS304		SUS316	SUS316L	Hastelloy-C	Specially specified	
⑥ MATERIAL FOR PROTECTION TUBE "U" (See page 4)	METAL	0	★ SUS304		NONMETAL	5	★ Pure Al ₂ O ₃ JIS PTO (99.5%) / DIN 710 (99.7%)	
		1	SUS316			6	Al ₂ O ₃ JIS PT1 (55%) / DIN 610 (58%)	
		2	SUS316L			7	Al ₂ O ₃ JIS PT2 (45%)	
		3	Hastelloy-C			8	Quartz-"QT"	
		4	Specially specified			9	Specially specified	

■ ORDERING EXAMPLE

400 C - E 4 1 1 - A A E D - 1 5 1 1 / A
 ① ② ③ ④ ⑤ ⑥ ⑦ ⑧ ⑨ ⑩ ⑪ ⑫ ⑬ ⑭ ⑮

■ KEY

"★"—STANDARD CODE

MODEL SELECTIONS

ITEMS	SPEC.	RTD				THERMOCOUPLE								
⑦ ELEMENT (See page 1~3)	A	★ Pt100Ω DIN 43760 JIS 1606 BS 1904 IEC 751				B	B ELEMENT	K	K ELEMENT	T	T ELEMENT			
		X	Specially specified				R	R ELEMENT	E	E ELEMENT	Y	Specially specified		
	S		S ELEMENT				J	J ELEMENT						
⑧ RTD ENCLOSED / HOT JUNCTION OF T/C (See page 2)	RTD				THERMOCOUPLE									
	A	B	C	D	E	F								
★ Ceramic enclosure	Specially specified	★ Ungrounding style	Grounding style	Exposed style	Specially specified									
⑨ INSULATIONS & BUILT-IN METHOD	A	★ Manufacture's standard				J	Specified							
	B	Silicon tubing (Less than 150°C)				Note: The Manufacturer's standard "A" are as below: ① MgO filling insulations are adopted when RTD / Thermocouple is used for anti-vibration. ② The teflon tubing insulation would be adopted when the operating temp. of RTD or thermocouple are less than 200°C ③ MgO filling insulations are used in the RTD versions when the operating temp. exceeded 200°C. ④ Ceramic tubing insulations are employed in the thermocouples when the operating temp. exceeded 200°C.								
	C	Teflon tubing (Less than 200°C)												
	D	Ceramic tubing Al ₂ O ₃ (Less than 1800°C)												
	E	MgO filled (Less than 2200°C)												
	F	BeO filled (Less than 2000°C)												
	G	Built-in sheath unit (Less than 950°C)												
	H	Built-in sheath unit with spring loaded (Less than 950°C)												
⑩ BUILT-IN Q'TY	S	★ 1 PAIR		D	2 PAIRS							T	3 PAIRS	
⑪ O.D. OF PART "N"	GENERAL		0	1	2		3							
			★ None	Same as "U"	With a support according to the maker standard		Specially specified							
	WITH LEAD WIRE / OF SHEATH													
	RTD					THERMOCOUPLE EXTENSION WIRE								
	0	★ Lead wire exposed				0	★ Lead wire exposed							
	1	PVC extension cable 50C / 0.18x1.25 ² , -20~+80°C				1	Hot resistance PVC 1C / 0.32, -10~+100°C							
	2	PVC extension cable 30C / 0.18x0.75 ² , -20~+80°C				2	Hot resistance PVC 1C / 0.65, -10~+100°C							
						3	Glass fiber 4C / 0.32, 10~270°C							
	3	PTFE extension cable 30C / 0.18x0.75 ² , -100~+260°C				4	Glass fiber 4C / 0.65, 10~270°C							
						5	Teflon 7C / 0.32, -100~+260°C							
4	Specially specified				6	Teflon 7C / 0.65, -100~+260°C								
					7	Specially specified								
⑫ LENGTH OF "N"	0		1		2		3		4					
	★ None		50 mm		100 mm		150 mm		Specially specified					
⑬ O.D. OF PART "U"	METAL				NONMETAL				SHEATH				8	Specially specified
	0	6 mm	4	15 mm	0	6 mm	4	15 mm	0	0.5 mm	4	3.2 mm		
	1	★ 8 mm	5	17 mm	1	8 mm	5	17 mm	1	1.0 mm	5	4.8 mm		
	2	10 mm	6	22 mm	2	10 mm	6	21 mm	2	1.6 mm	6	6.0 mm		
	3	12 mm	7	27 mm	3	13 mm	7	25 mm	3	2.2 mm	7	8.0 mm		
⑭ LENGTH OF "U"	0		1	★ 100 mm		2	150 mm		3	200 mm		4	250 mm	
	5		300 mm	6	400 mm		7	500 mm		8	1000 mm		9	Specially specified
⑮ OPTIONS	A	★ Not required				B	Signal conditioner				C	Thermowell		
	D	Signal conditioner & Thermowell								E	Specified			

HEAD-MOUNTED SIGNAL CONDITIONERS (450 / 451 SERIES)

■ SPECIFICATIONS

ITEMS	RESISTANCE BULB (RTD)	THERMOCOUPLES
MODEL NO.	450	451
SENSING ELEMENT	Pt100Ω 2, 3-wire	R, S, K, E, J, T
INPUT	RTD or T/C sensor	
OUTPUT	4~20mA DC 2-wire system	
POWER SUPPLY	9~36V DC	
LOAD RESISTANCE	600Ω at 24V	500Ω at 24V
ACCURACY	±0.1% F.S.	±0.25% F.S.
ZERO / SPAN ADJUSTMENT	±5% of span adjustable	
CIRCUIT PROTECTION	Intrinsically safe EEx ia IIC T4	
SENSOR EXCITED	1mA DC	2mA min. for span
DROP OF LOOP TEST	40~200mV (Between LT / PS-)	
RESPONSE TIME	50 Msec (0~90%)	250 Msec (0~90%)
LINEARITY	±0.02%	±0.25%
COLD JUNCTION COMPENSATION	—	K,E,J,T : ±0.5°C max. R,S : ±1°C max.
BURNOUT PROTECTION	Upscale ≥23mA DC	
ISOLATION	250Vrms between input/output/case	
TEMP. CO-EFFICIENT	±0.02% / °C	±0.015% / °C
MEASURING RANGE	The standard is referred to the calibrated range table and special range is also available	
AMBIENT TEMP.	-5~+70°C 90%RH	
MODULE HOUSING	Die-cast aluminum alloy with epoxy coating	

■ MODEL SELECTIONS

ITEMS	CODE	SPECIFICATIONS
MODEL	450	RTD CONVERTER
	451	T/C CONVERTER
ISOLATION	A	Not required
	B	Required
CALIBRATED RANGE	A } K	See table of standard calibrated range
	A	RTD 100Ω DIN43760
INPUT	B	Specially specified of RTD
	R	R-element of T/C
	S	S-element of T/C
	K	K-element of T/C
	E	E-element of T/C
	J	J-element of T/C
	T	T-element of T/C
	X	Specially specified of T/C

■ RANGE SETTING OF T/C

Measuring range (°C)		SWITCH				
K, E, J, T	R, S	1	2	3	4	5
0~1000	0~1600				●	
0~500	0~800				●	■
200~700	400~1200			●		■
350~850	600~1400		●			■
500~1000	800~1600	●				■

KEY: ● — Switch in ON ; ■ — Jumper short

■ STANDARD CALIBRATED RANGE

CODE	RTD	THERMOCOUPLE
A	-50~+80°C	0~+100°C
B	-50~+50°C	0~+150°C
C	-20~+80°C	0~+200°C
D	0~+50°C	0~+300°C
E	0~+100°C	0~+400°C
F	0~+150°C	0~+500°C
G	0~+200°C	0~+600°C
H	0~+300°C	0~+800°C
I	0~+400°C	0~+1000°C
J	0~+500°C	0~+1200°C
K	0~+600°C	0~+1400°C

■ DIMENSIONS

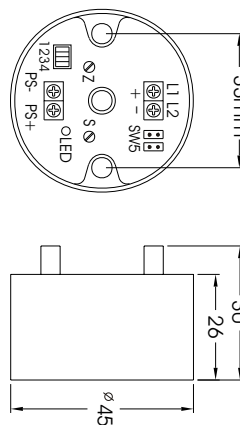

■ WIRING CONNECTIONS

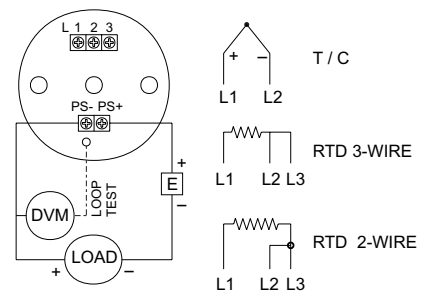

DOERS TECHNOLOGY CORPORATION

4F, NO. 1, LANE 11, TZU CHIANG STREET, TU-CHENG INDUSTRIAL PARK, TAIPEI COUNTY, TAIWAN 23678

<http://www.doers.com.tw>

E-mail : doers.tech@msa.hinet.net

TEL : 886-2-22682689

FAX : 886-2-22681248

